



Graver Technologies

**CONSLER™ FILTRATION PRODUCTS**

# **Air Intake Filters**



**A Better Process**

The operating and maintenance costs of compressors, blowers, turbines and other air handling equipment are dramatically affected by contaminants at the air intake. As these contaminants move further downstream, they can also have an undesirable affect on process controls and instrumentation, pneumatic tools, and other air-operated equipment. Proper air intake filtration can prevent equipment corrosion and the fouling of internal components, thus ensuring that your equipment is operating at peak performance and ultimately extending the life of your equipment.

Graver Technologies Consler Filtration Products also manufactures Series PFS (Single Stage) and PFD (Two Stage) housings. Standard sizes are rated from 2,500 CFM to 40,000 CFM and other sizes are available upon request. All models are constructed from carbon steel that is primed and enamel coated, or stainless steel. Ask for Bulletin GTX-162 for more information, or call your local Consler Filtration Products authorized representative.

At Graver Technologies, we don't limit you to just three standard panel filter elements. We can vary features such as the number of pleats, the type of filter media and the size of the frame to create a virtually limitless array of panel filter elements to fit almost every application. Call us with your application.

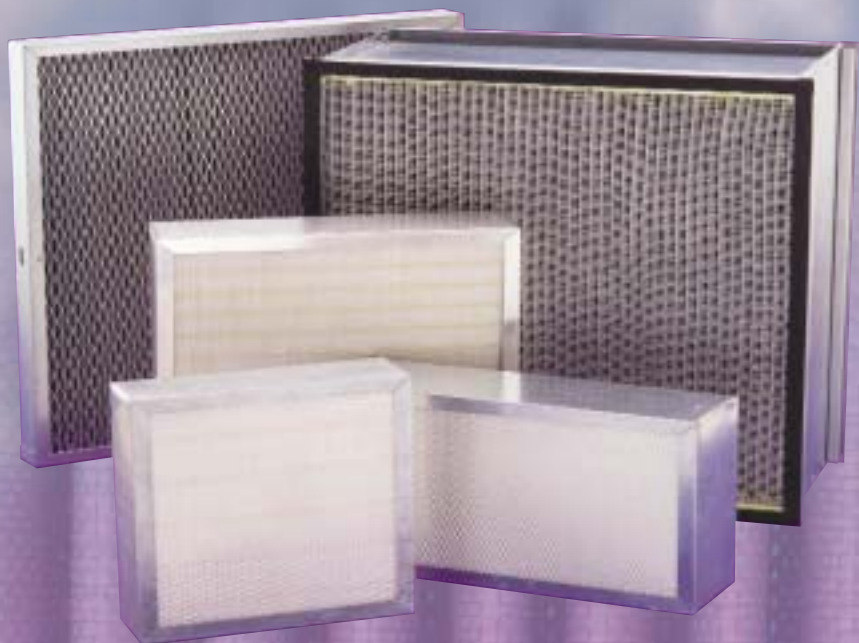
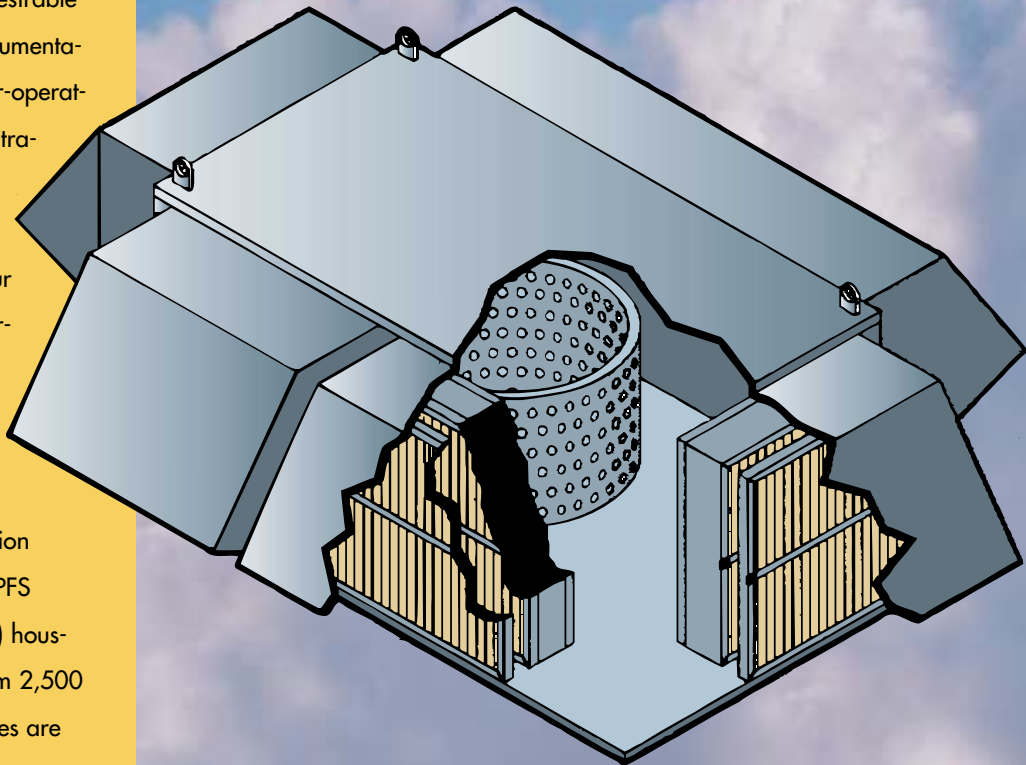



Graver Technologies' panel filter element number GT-23104 is a heavy duty first stage element designed to provide smooth air flow in industrial air intake applications where multi-stage filtration is required, such as compressors and turbines.

**Technical Specifications:**

- Actual size: 23 1/2" x 23 1/2" x 1 1/2"
- Initial pressure drop: .6" W.C at 2500 SCFM
- 36 square feet of filtration area
- Filtration efficiency: 98% of 10 microns
- 87 pleats of durable and washable synthetic fiber media
- Element weight: 7 lbs.



Graver Technologies' panel filter element number GT-23105 is a heavy duty first stage element designed to provide smooth air flow in industrial air intake applications where multi-stage filtration is required, such as compressors and turbines.

**Technical Specifications:**

- Actual size: 23 1/2" x 23 1/2" x 1 1/2"
- Initial pressure drop: .8" W.C at 2500 SCFM
- 29 square feet of filtration area
- Filtration efficiency: 98% of 10 microns
- 70 pleats of durable and washable polyester/felt media with reinforced epoxy coated screen on both sides of the media
- Element weight: 8 lbs.



Graver Technologies' panel filter element number GT-23106 is a heavy duty single stage element designed to provide fine filtration and smooth air flow in industrial air intake applications such as fans and blowers. It can also be used as a pre-filter in applications where multi-stage filtration is required, such as compressors and turbines.

**Technical Specifications:**

- Actual size: 23 1/2" x 23 1/2" x 2"
- Initial pressure drop: 1.1" W.C at 2500 SCFM
- 42 square feet of filtration area
- Filtration efficiency: 98% of 10 microns
- 70 pleats of durable and washable polyester/felt media with reinforced epoxy coated screen on both sides of the media
- Element weight: 11.5 lbs.

**Standard Features:**

In addition to the standard features listed below, the surface area of the media and the number of pleats on all of Graver Technologies' panel filter elements have been optimized to provide the best combination of filtration efficiency, high flow, low pressure drop and high dust holding capacity.

- Totally interchangeable with original equipment
- Rugged, weather resistant galvanized steel frame
- Handling strap for ease of installation
- Air flow direction label to ensure proper installation
- Pleated media for extended filter area
- High dirt holding capacity
- Low initial pressure drop
- Element can be cleaned and reused

**"Value Added" Features:**

While some manufacturers provide a number of standard and "value added" features, only Graver Technologies provides all of the following "value added" features to clearly differentiate ourselves from all other manufacturers.

- Filter media is potted with adhesive ON ALL 4 SIDES to prevent bypass
- Superior packaging – 275# double-wall, corrugated material (2 elements per box)
- Flattened, expanded galvanized metal blowout grid both upstream and downstream
- 2-piece frame design with expanded metal encapsulated in the adhesive, resulting in increased frame rigidity
- Meets or exceeds the original manufacturer's specifications
- IN STOCK and ready for shipment within 24 hours



# Graver Technologies



Graver Technologies • Honeoye Falls, New York  
Manufacturing and Development site  
for Consler Filtration Products



Graver Technologies • Glasgow, Delaware  
Corporate Headquarters

Graver Technologies designs, engineers and manufactures Consler brand filtration systems using pleated elements and ASME code vessels. You'll find our filters in a broad range of industrial applications including chemical processing, natural gas, power generation, and industrial gas production. In addition to a wide range of standard filters and vessels, Graver Technologies specializes in custom engineered solutions to meet specific application requirements.

Graver Technologies is a certified supplier to numerous OEM's of pumps, compressors, turbines, and vacuum pumps. With over 30 years experience engineering and manufacturing filtration solutions, the Consler brand has earned a solid reputation for high quality products, on-time delivery, and superior customer service. Graver Technologies Filtration Products is committed to total customer satisfaction and delivering exceptional value for our customers.

Graver Technologies is a member of the Marmon Group of companies which has annual revenues of over \$7 billion worldwide. Whether it's around the corner or around the globe, Graver Technologies Products offers our customers the flexibility of working with a small company and the financial strength of a large corporation.

## Compressed Air/Gas Filters



## Filter Skid Packages



## Air Intake, Exhaust & Vacuum Filters



## Coalescing Filters & Separators



## HEPA & ULPA Filters and Pleat Packs



## OEM Filter Cartridges and Components



## Single and Multi-Cartridge Designs



## Custom Designs

Corporate Headquarters  
200 Lake Drive  
Glasgow, Delaware 19702 USA  
Telephone: 302.731.1700  
Fax: 302.731.1707  
E-Mail: info@gravertech.com

Graver Technologies Europe GmbH  
Wolf-Hirth – Straße 9  
73730 Esslingen-Sirnau  
Germany  
Telephone: 49.711.31.54.71.60  
Fax: 49.711.31.54.71.70

Customer Service  
Toll-free (in U.S.): 800.533.6623

Manufacturing/Distribution Centers  
Glasgow, Delaware  
Honeoye Falls, New York  
Newark, New Jersey  
Esslingen, Germany

## Graver Technologies • Consler Filtration Products

300 West Main Street, Honeoye Falls, NY 14472 • USA  
716.624.1330 • 800.321.4789 • Fax: 716.624.1205  
www.gravertech.com • info@gravertech.com

